

ALFRA PROFILE RAIL CUTTING DEVICE[®] – PSG 5+[®] WITH HYDRAULIC CYLINDER

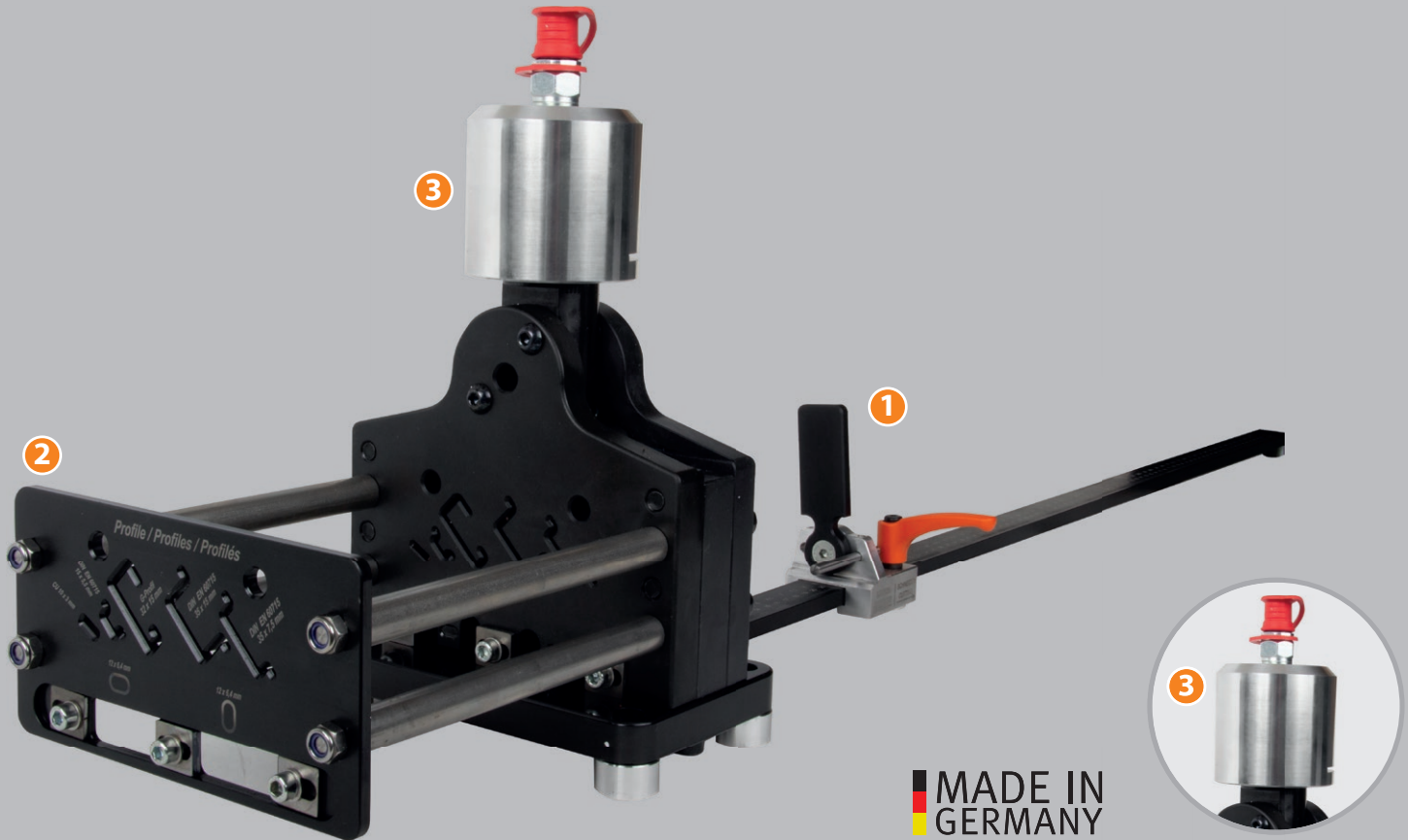

MADE IN GERMANY

- 1** Limit stop with mm/inch laser-engraved
- 2** Profile throughput is optimised for lowest-possible cutting play
- 3** Hydraulic cylinder with safety lock nipple 1/4" NPT

For mounting rails, for hydraulic operation for **cutting to length and hole punching longitudinally and transversely** on the depicted mounting rails.

- With reinforced cam located directly above the shear plate
- Lower force application due to improved force transmission
- Burr-free cutting to length without waste
- Maintenance-free
- Anodised, laser-engraved length limit stop 1,000 mm with guiding device for precise angled cutting to length, with millimetre and inch scaling
- Shear plate can be re-ground, puncher replaceable
- Custom-made products are also possible (please send us a sample rail of about 1,000 mm length)
- Hydraulic connection: Hydraulic safety lock nipple 1/4" NPT

Scope of delivery

with transverse and longitudinal hole puncher 12 x 6.4 mm, 1000 mm length limit stop and guidance fixture incl. G-profile as per EN 60715, with hydraulic cylinder

Prod.-No.

03003G

Mounting rail
35mm/7.5
as per EN 60715

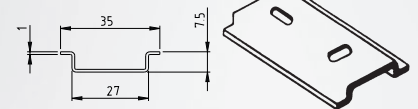

Mounting rail
35 mm/15
as per EN 60715

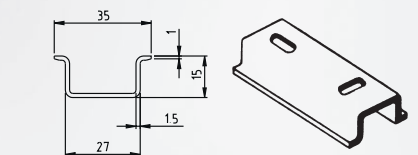

Mounting rail
15 mm/5.5
as per EN 60715

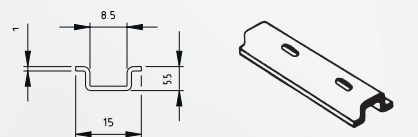

G-profile
as per EN 60715

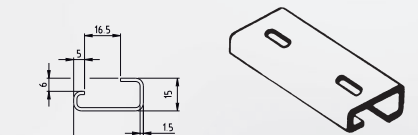

Copper ground rails
10 mm x 3 mm

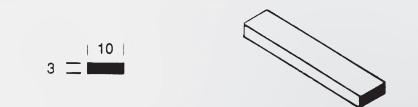

Spare parts for universal cutting and punching device

	Prod.-No.
Spare puncher + die 12 x 6.4 mm f. longitudinal hole	03005
Spare puncher + die 12 x 6.4 mm f. transverse hole	03006
Spare puncher + die 5.5 mm f. round hole	03007
Spare puncher + 6.0 mm f. round hole	03008
Special versions for mounting rails or flat rails, also in stainless steel or aluminium or plastic on request	03011